

### Description

The DFI600HF12I4ME1 is a Half Bridge IGBT Power Module. It integrates high performance IGBT chips designed for the applications such as High Power supply and Motor control.



### Features

- Blocking voltage:1200V
- Low saturation voltage  $V_{CE(sat)}$
- Low Switching Losses
- 175°C maximum junction temperature
- Thermistor inside

### Applications

- High Power Switching Applications
- Motor Drives
- Solar inverter Systems
- Wind Turbines

### Circuit diagram

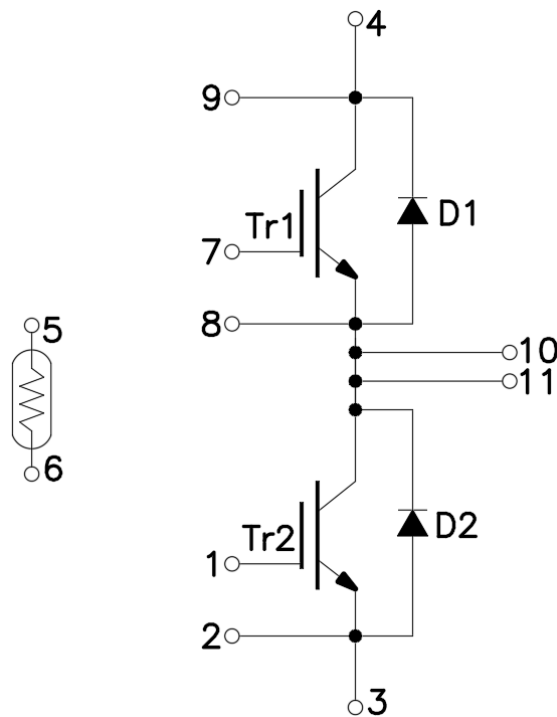

Figure 1. Out drawing & circuit diagram for DFI600HF12I4ME1

### Pin Configuration and Marking Information

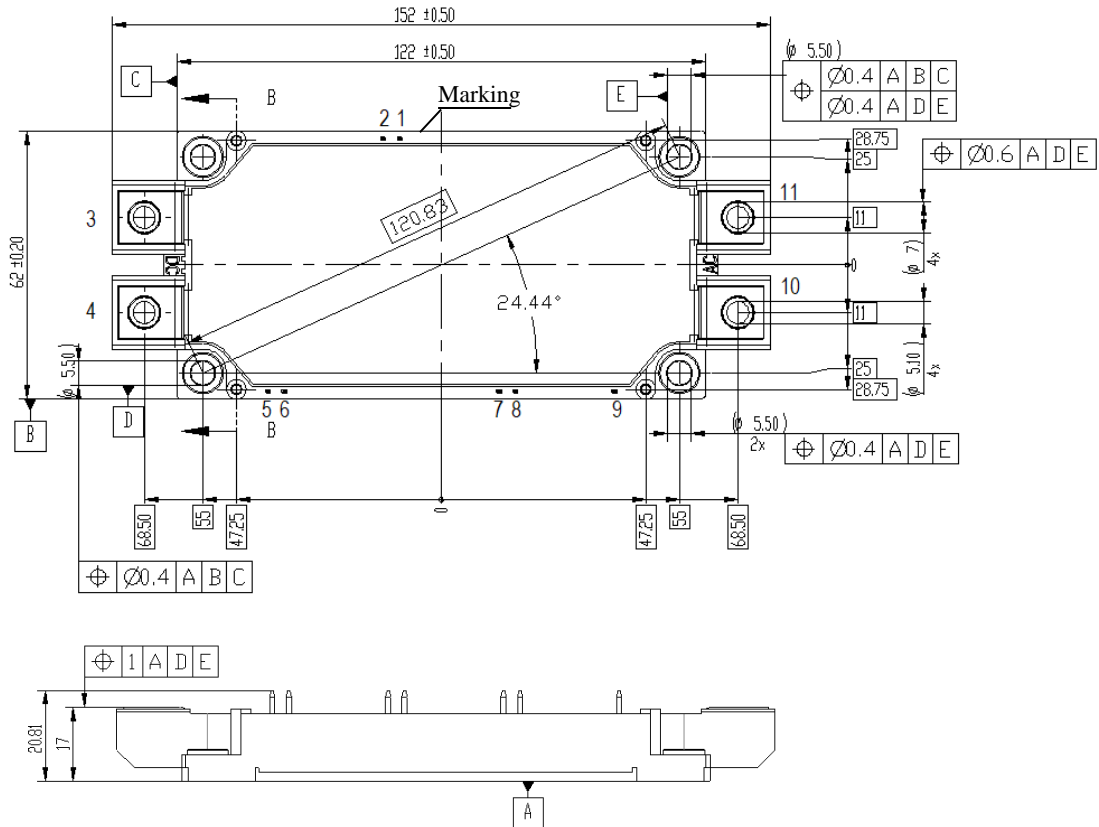

Figure 2. Pin configuration

### Module

Parameter	Conditions	Value	Unit
Isolation Voltage	RMS, f = 50Hz, t = 1 min	3.4	KV
Material of module baseplate	-	Cu	-
Creepage distance	terminal to heatsink terminal to terminal	14.5 13	mm
Clearance	terminal to heatsink terminal to terminal	12.5 10	mm
CTI	-	>200	-
Module lead resistance, terminals – chip	T <sub>c</sub> = 25°C	0.8	mΩ
Mounting torque for module mounting	M5, M6	3 to 6	Nm
Weight	-	420	g

### Maximum Ratings (T<sub>j</sub>=25°C unless otherwise specified)

Symbol	Parameter	Conditions	Ratings	Unit
V <sub>CES</sub>	Collector-Emitter Voltage	G-E Short	1200	V
V <sub>GES</sub>	Gate-Emitter Voltage	C-E Short	±20	V
I <sub>C</sub>	DC Continuous Collector Current	T <sub>C</sub> =100°C	800	A
I <sub>CM</sub>	Pulse Collector Current	t <sub>p</sub> =1ms, Note1	1600	A
P <sub>C</sub>	Maximum Power Dissipation	T <sub>C</sub> =25°C, T <sub>j</sub> =175°C(IGBT)	5000	W
I <sub>F</sub>	Diode Forward Current	-	700	A
I <sub>FRM</sub>	Repetitive peak forward Current	t <sub>p</sub> =1ms, Note1	1400	A
I <sup>2</sup> t	I <sup>2</sup> t-value	V <sub>R</sub> =0V, t <sub>p</sub> =10ms, T <sub>j</sub> =125°C(Diode)	40000	A <sup>2</sup> s
I <sup>2</sup> t	I <sup>2</sup> t-value	V <sub>R</sub> =0V, t <sub>p</sub> =10ms, T <sub>j</sub> =150°C(Diode)	37500	A <sup>2</sup> s
T <sub>j</sub>	junction temperature	-	-40 to 175	°C
T <sub>stg</sub>	Storage temperature	-	-40 to 125	°C

Note1: Pulse width limited by maximum junction temperature

### NTC characteristics

Symbol	Parameter	Condition	Value			Unit
			Min.	Typ.	Max.	
R <sub>25</sub>	Resistance	T <sub>C</sub> =25°C	-	5	-	kΩ
ΔR/R	Deviation of R100	T <sub>C</sub> =100°C, R <sub>100</sub> =493Ω	-5	-	5	%
P <sub>25</sub>	Power dissipation	T <sub>C</sub> =25°C	-	-	20	mW
B <sub>25/50</sub>	B-value	R <sub>2</sub> = R <sub>25</sub> exp [B <sub>25/50</sub> (1/T <sub>2</sub> - 1/(298,15 K))]	-	3375	-	K
B <sub>25/80</sub>	B-value	R <sub>2</sub> = R <sub>25</sub> exp [B <sub>25/80</sub> (1/T <sub>2</sub> - 1/(298,15 K))]	-	3411	-	K
B <sub>25/100</sub>	B-value	R <sub>2</sub> = R <sub>25</sub> exp [B <sub>25/100</sub> (1/T <sub>2</sub> - 1/(298,15 K))]	-	3433	-	K

### IGBT Electrical characteristics (T<sub>j</sub>=25°C unless otherwise specified, chip)

Symbol	Item	Condition		Value			Unit
				Min.	Typ.	Max	
V <sub>CE(sat)</sub> (Chip)	Collector-Emitter Saturation Voltage	I <sub>C</sub> =600A V <sub>GE</sub> =15V	T <sub>j</sub> =25°C	-	1.65	1.95	V
			T <sub>j</sub> =150°C	-	1.85	-	V
			T <sub>j</sub> =175°C	-	1.90	-	V
V <sub>GE(th)</sub>	Gate-Emitter threshold Voltage	I <sub>C</sub> =25mA, V <sub>CE</sub> =V <sub>GE</sub>		5.0	-	6.8	V
Q <sub>G</sub>	Gate charge	V <sub>GE</sub> = -15V to +15V		-	4.4	-	uC
R <sub>Gint</sub>	Internal gate resistor	-	T <sub>j</sub> =25°C	-	1.1	-	Ω
C <sub>ies</sub>	Input Capacitance	V <sub>CE</sub> =25V, V <sub>GE</sub> =0V f=1MHz	T <sub>j</sub> =25°C	-	52	-	nF
C <sub>res</sub>	Reverse transfer Capacitance			-	1.85	-	nF
I <sub>CES</sub>	Collector- Emitter Cut off Current	V <sub>CE</sub> =1200V, V <sub>GE</sub> =0V	T <sub>j</sub> =25°C	-	-	1	mA
I <sub>GES</sub>	Gate-Emitter Leakage Current	V <sub>GE</sub> = 20V, V <sub>CE</sub> =0V	T <sub>j</sub> =25°C	-	-	1.5	uA
t <sub>d(on)</sub>	Turn-on delay time	V <sub>CC</sub> =600V I <sub>C</sub> = 600A V <sub>GE</sub> =+15V/-8V R <sub>G</sub> =1.0Ω Inductive load	T <sub>j</sub> =25°C	-	215	-	ns
			T <sub>j</sub> =125°C	-	220	-	
			T <sub>j</sub> =175°C	-	220	-	
t <sub>r</sub>	Rise time		T <sub>j</sub> =25°C	-	60	-	ns
			T <sub>j</sub> =125°C	-	73	-	
			T <sub>j</sub> =175°C	-	75	-	
t <sub>d(off)</sub>	Turn-off delay time		T <sub>j</sub> =25°C	-	490	-	ns
			T <sub>j</sub> =125°C	-	565	-	
			T <sub>j</sub> =175°C	-	610	-	
t <sub>f</sub>	Fall time	T <sub>j</sub> =25°C	-	85	-	ns	
		T <sub>j</sub> =125°C	-	185	-		
		T <sub>j</sub> =175°C	-	295	-		
E <sub>on</sub>	Turn-on power dissipation	T <sub>j</sub> =25°C	-	73.31	-	mJ	
		T <sub>j</sub> =125°C	-	103.2	-		
		T <sub>j</sub> =175°C	-	121.6	-		
E <sub>off</sub>	Turn-off power dissipation	T <sub>j</sub> =25°C	-	50.4	-	mJ	
		T <sub>j</sub> =125°C	-	65.79	-		
		T <sub>j</sub> =175°C	-	80.39	-		
R <sub>th(j-c)</sub>	Thermal Resistance, Junction to Case (IGBT)		-	0.03	-	°C/W	
R <sub>th(c-s)</sub>	Thermal Resistance, Case to sink (Conductive Grease applied)		-	0.02	-	°C/W	

### Freewheeling Diode Electrical characteristics ( $T_j=25^\circ\text{C}$ unless otherwise specified, chip)

Symbol	Item	Condition	Value			Unit	
			Min.	Typ.	Max		
$V_F$	Diode Forward Voltage	$I_F=600\text{A}, V_{GE}=0\text{V}$	$T_j=25^\circ\text{C}$	-	1.7	2.1	V
			$T_j=150^\circ\text{C}$	-	1.7	-	
			$T_j=175^\circ\text{C}$	-	1.65	-	
$t_{rr}$	Reverse recovery time	(Switch side) $V_{CC}=600\text{V}$ $I_C=600\text{A}$	$T_j=25^\circ\text{C}$	-	0.51	-	us
			$T_j=125^\circ\text{C}$	-	0.675	-	
			$T_j=175^\circ\text{C}$	-	0.9	-	
$I_{RM}$	Peak reverse recovery Current	$V_{GE}=+15\text{V}/-8\text{V}$ $R_G=1.0\Omega$	$T_j=25^\circ\text{C}$	-	333	-	A
			$T_j=125^\circ\text{C}$	-	300	-	
			$T_j=175^\circ\text{C}$	-	291	-	
$Q_{rr}$	Recovered charge	(FRD side) $V_{rr}=600\text{V}$ $I_F=600\text{A}$ $V_{GE}=-8\text{V}$	$T_j=25^\circ\text{C}$	-	54.43	-	uC
			$T_j=125^\circ\text{C}$	-	85.92	-	
			$T_j=175^\circ\text{C}$	-	120.81	-	
$E_{rr}$	Reverse recovered energy	Inductive load switching operation	$T_j=25^\circ\text{C}$	-	17.65	-	mJ
			$T_j=125^\circ\text{C}$	-	28.16	-	
			$T_j=175^\circ\text{C}$	-	41.15	-	
$R_{th(j-c)}$	Thermal Resistance, Junction to Case (Diode)		-	0.05	-	$^\circ\text{C}/\text{W}$	
$R_{th(c-s)}$	Thermal Resistance, Case to sink (Conductive Grease applied)		-	0.022	-	$^\circ\text{C}/\text{W}$	

### Test Conditions

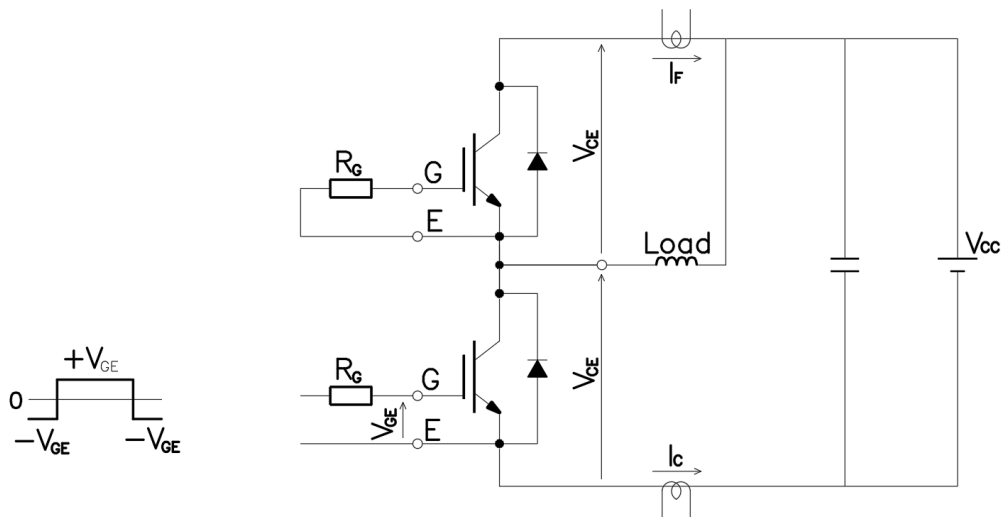

Figure 3. Switching time measure circuit

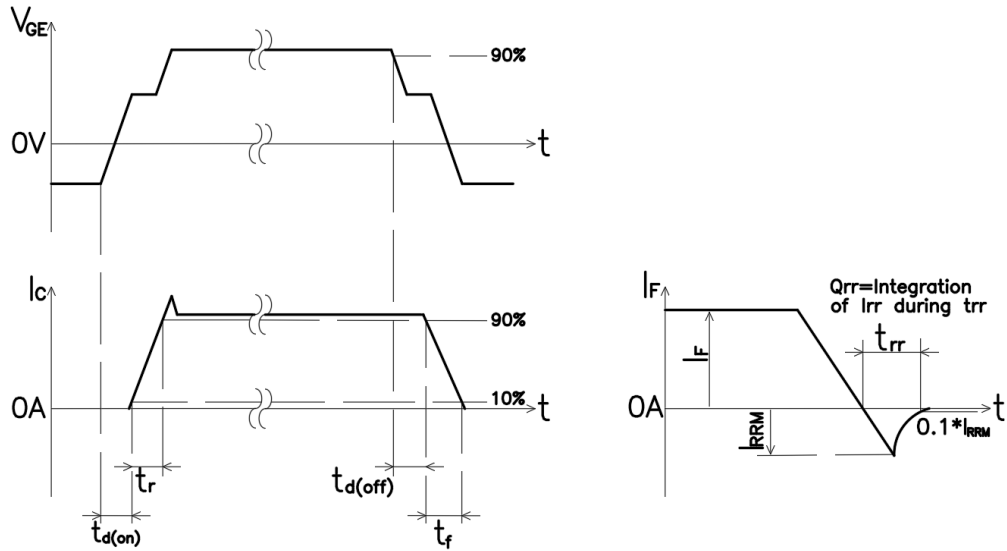

Figure 4. Switching time definition

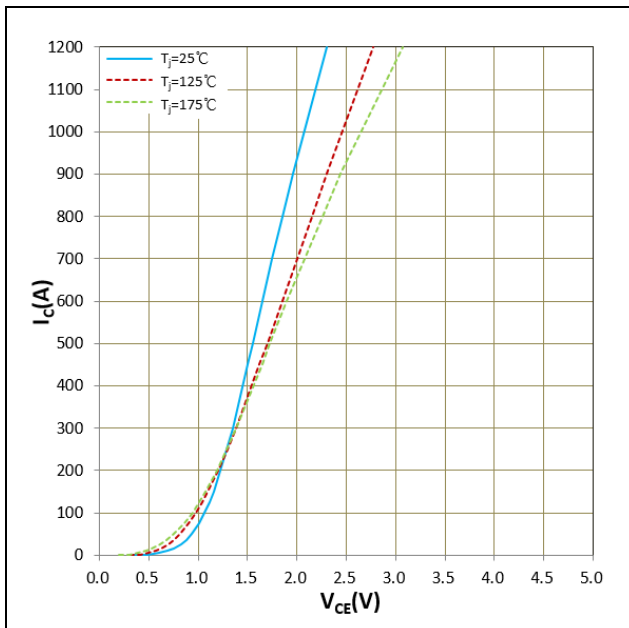

Figure 5.  $I_c$  vs  $V_{CE}$   
 $V_{GE} = 15V$

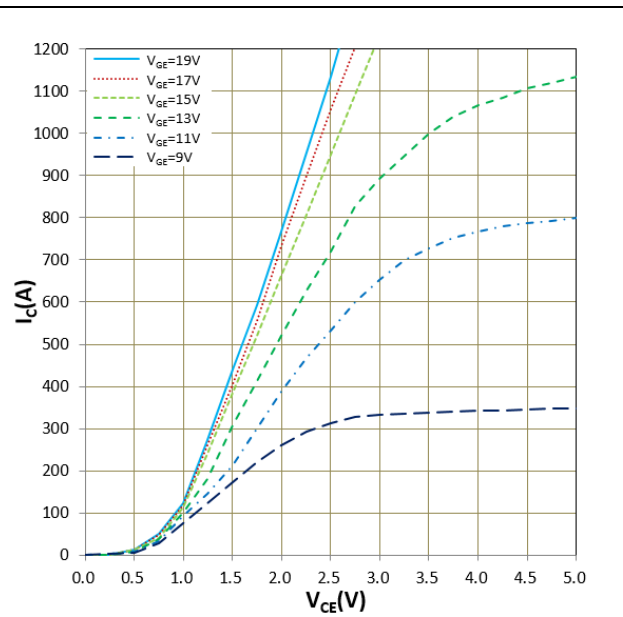

Figure 6.  $I_c$  vs  $V_{CE}$   
 $T_j = 175^\circ C$

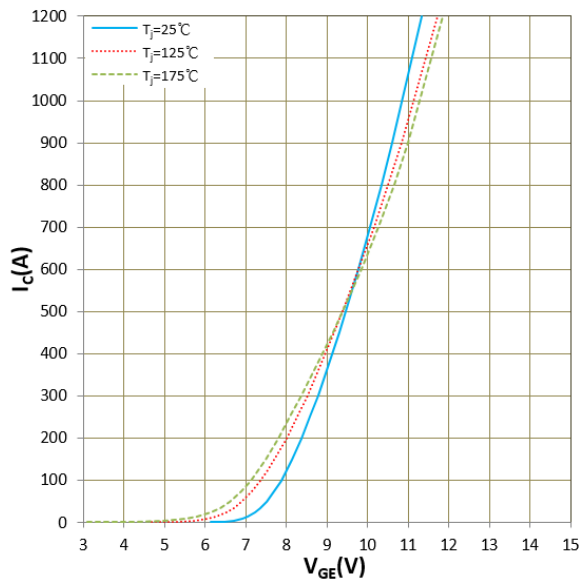

Figure 7.  $I_c$  vs  $V_{GE}$   
 $V_{CE} = 20V$

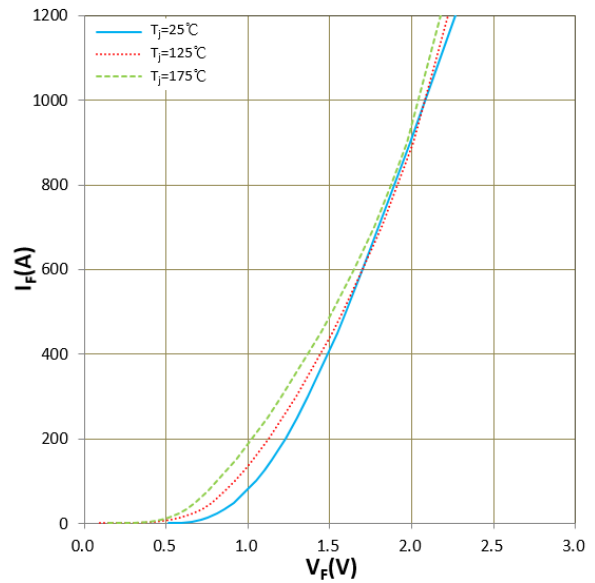

Figure 8.  $I_F$  vs  $V_F$

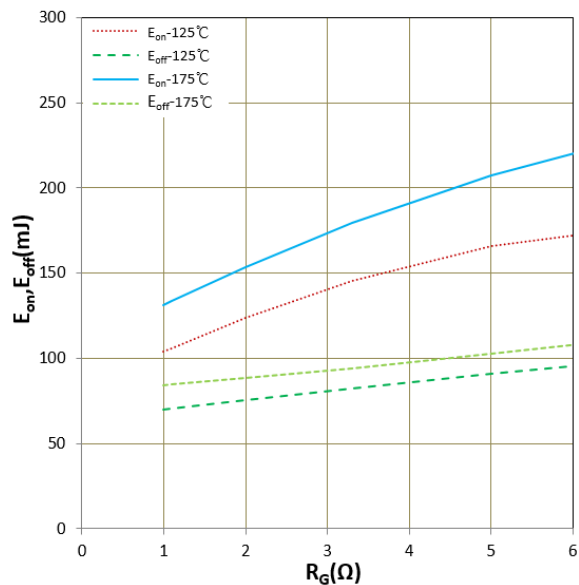

Figure 9.  $E_{on}$ ,  $E_{off}$  vs  $R_G$ (Typ)  
 $V_{CC} = 600V$ ,  $V_{GE} = +15V/-8V$ ,  $I_c = 600A$   
Inductive Load

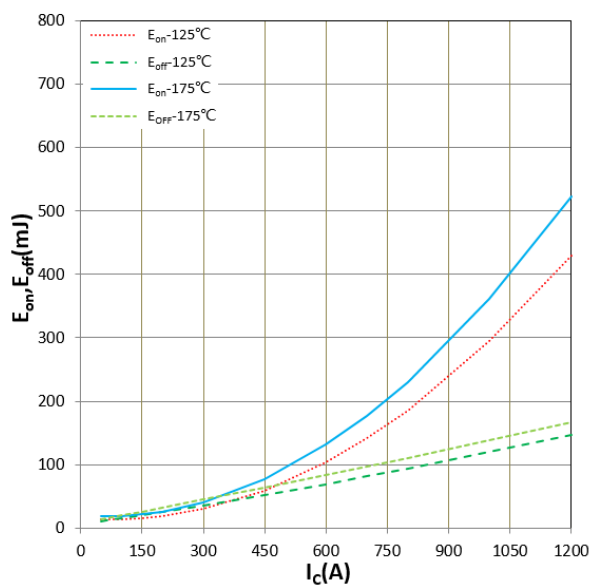

Figure 10.  $E_{on}$ ,  $E_{off}$  vs  $I_c$ (Typ)  
 $V_{CC} = 600V$ ,  $V_{GE} = +15V/-8V$ ,  $R_G = 1.0\Omega$   
Inductive Load

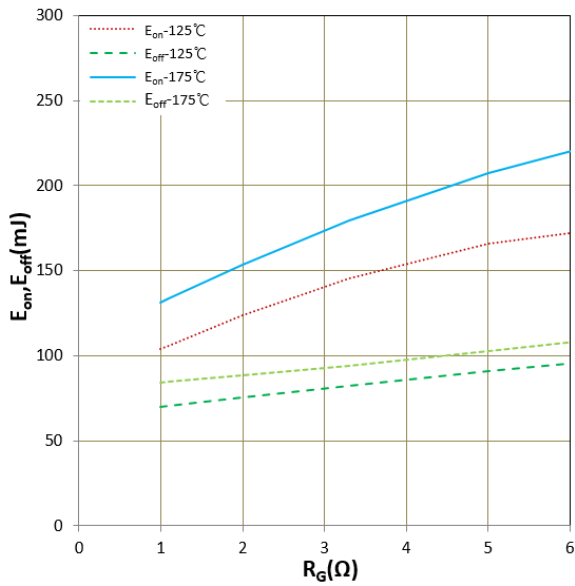

Figure 11. Err vs  $R_G$ (Typ)  
 $V_{CC}=600V$ ,  $V_{GE}=+15V/-8V$ ,  $I_F=600A$   
 Inductive Load

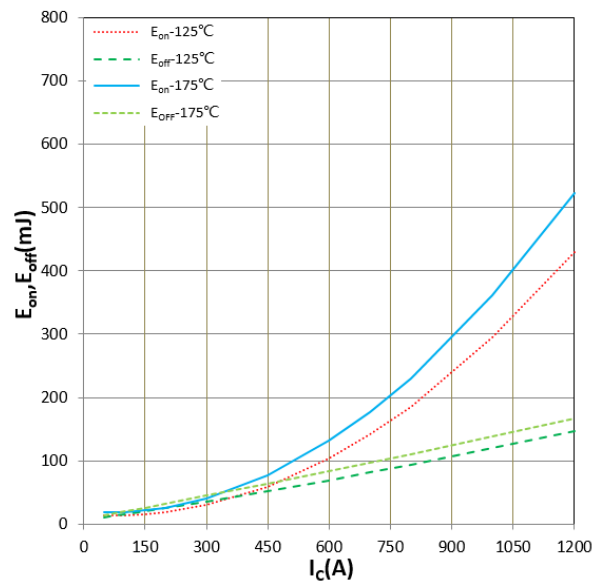

Figure 12.  $E_{err}$  vs  $I_c$ (Typ)  
 $V_{CC}=600V$ ,  $V_{GE}=+15V/-8V$ ,  $R_G=1.0\Omega$   
 Inductive Load

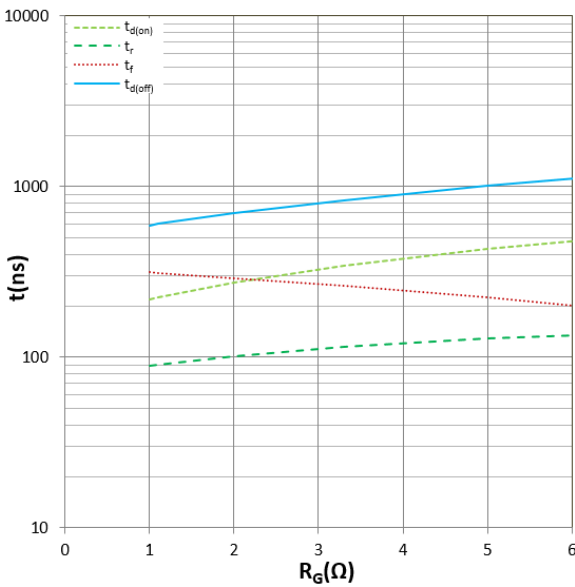

Figure 13. Switching time vs  $R_G$ (Typ)  
 $V_{CC}=600V$ ,  $V_{GE}=+15V/-8V$ ,  $I_c=600A$   
 $T_j=175^\circ C$ , Inductive Load

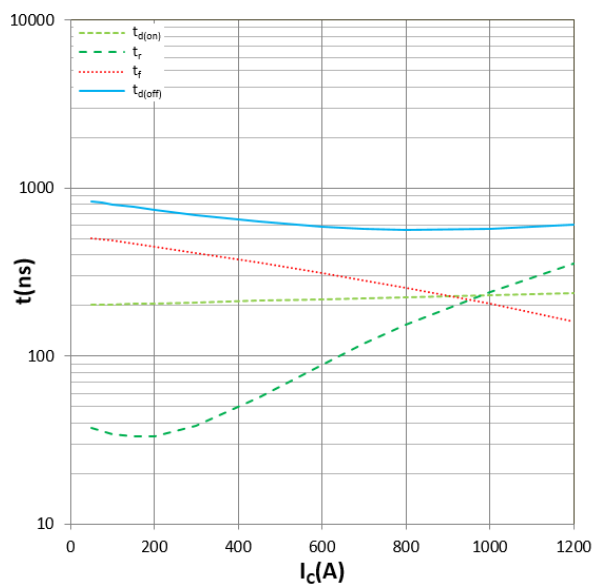

Figure 14. Switching time vs  $I_c$ (Typ)  
 $V_{CC}=600V$ ,  $V_{GE}=+15V/-8V$ ,  $R_G=1.0\Omega$   
 $T_j=175^\circ C$ , Inductive Load



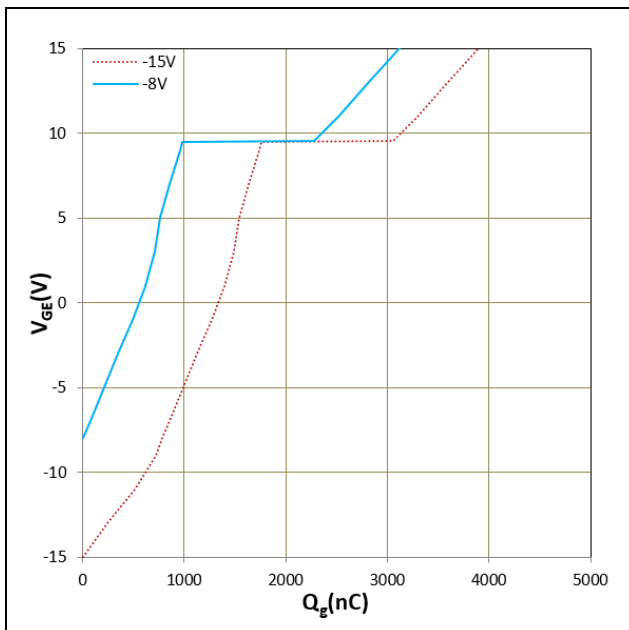

Figure 15. Gate charge

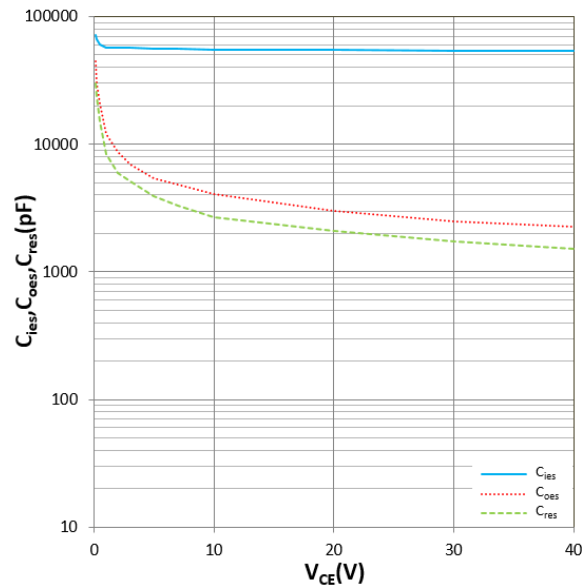

Figure 16.  $C_{ies}$ ,  $C_{oes}$ ,  $C_{res}$  vs  $V_{CE}$   
 $T_j = 25^\circ\text{C}$ ,  $f = 100\text{KHz}$

### IMPORTANT NOTICE:

This product data sheet describes the characteristics of this product for which a warranty is granted. Any such warranty is granted exclusively under the terms and conditions of the supply agreement. There will be no guarantee or of any kind for the product and its characteristics.

The data contained in this document is exclusively intended for technically trained staff. You and your technical departments will have to evaluate the product's suitability for the intended application and the completeness of the product data concerning such application.

Due to technical requirements, our product may contain dangerous substances. For information on the types in question, please contact the sales staff responsible for you.

Changes to this product data sheet are reserved.

Please contact the sales staff (Sales@leapers-power.com) for further information on the product, technology, delivery terms, conditions and prices.