

Description

The DFI50FB12P3D1 offer lower losses and higher energy for application such as motor drive, inverter and soft switching applications.

Features

- 1200V50 A, $V_{CE(sat)}(typ.) = 1.5V$
- Lower losses and higher energy
- Excellent short-circuit capability



Applications

- Motor drive
- Inverter
- Welding machines
- UPS

Circuit diagram

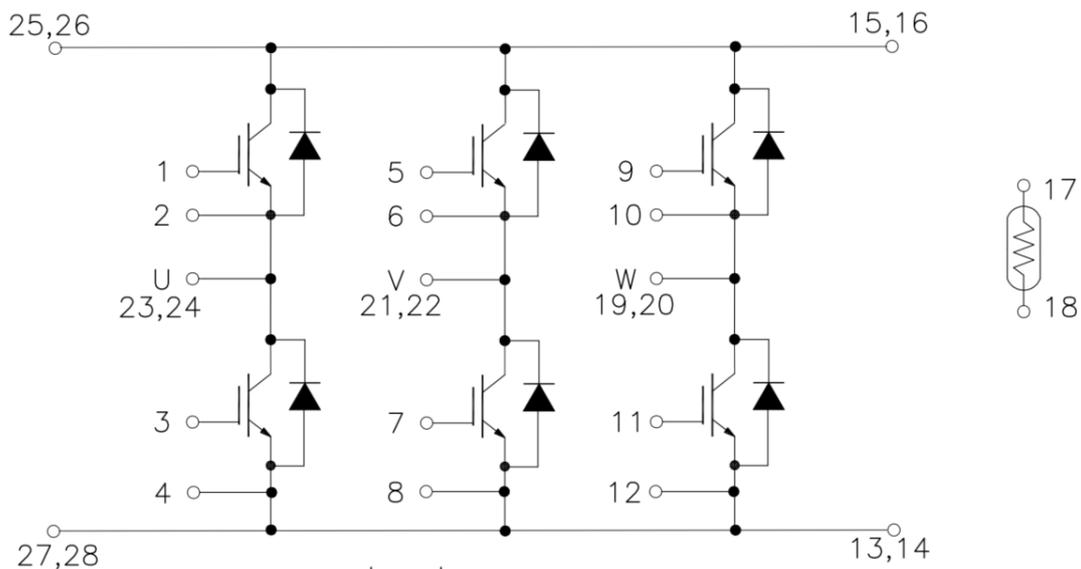

Figure 1. Out drawing & circuit diagram for DFI50FB12P3D1

Pin Configuration and Marking Information

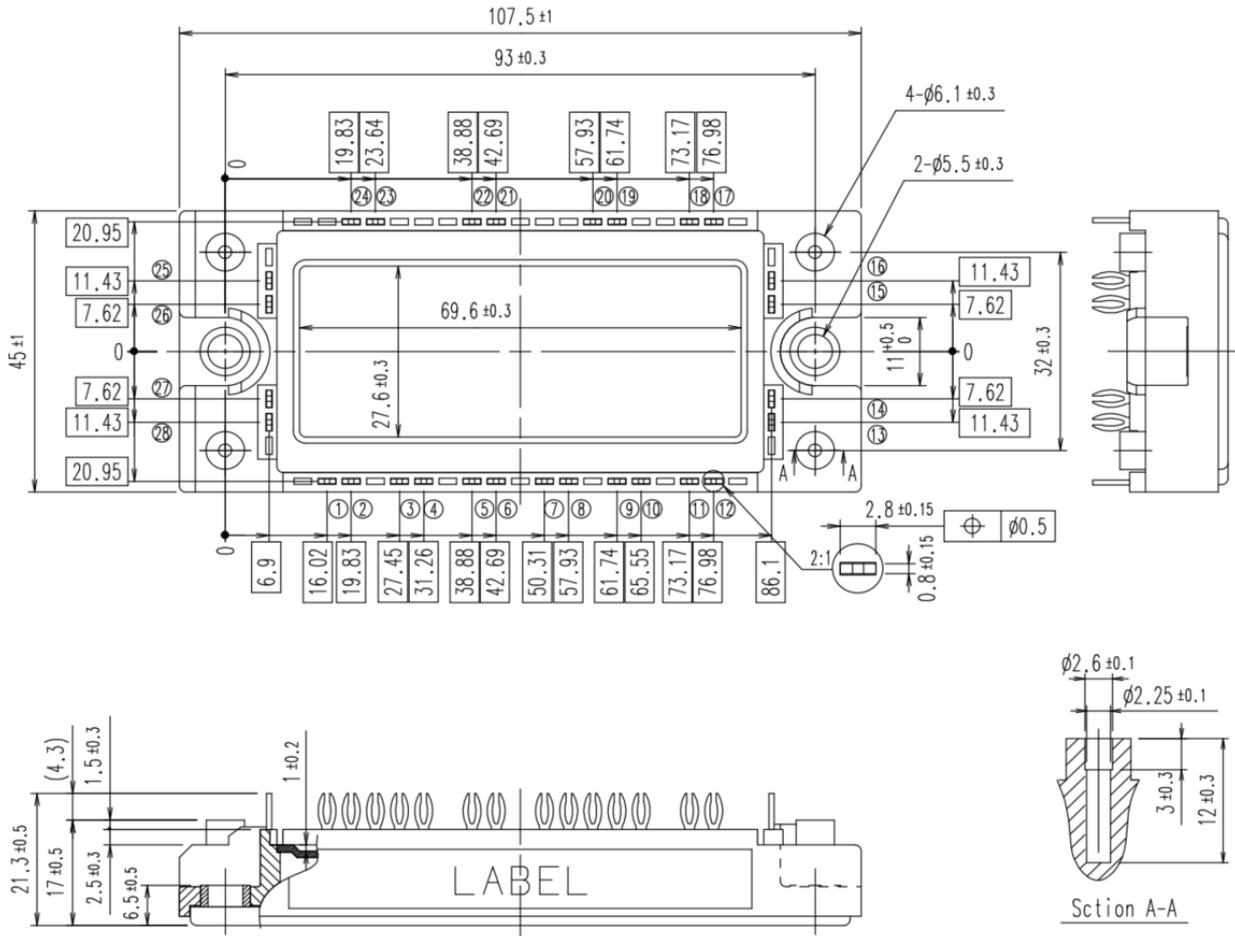

Figure 2. Pin configuration

Module

Parameter	Conditions	Value	Unit
Isolation Voltage	RMS, f = 50Hz, t = 1 min	2.5	KV
CTI	-	>200	-
Module lead resistance, terminals – chip	T _c = 25°C	0.8	mΩ
Mounting torque for module mounting	M5	3 to 6	Nm
Weight	-	175	g

Maximum Ratings (IGBT, Freewheeling Diode ,T_j=25°C unless otherwise specified)

Symbol	Parameter	Conditions	Ratings	Unit
V _{CES}	Collector-Emitter Voltage	G-E Short	1200	V
V _{GES}	Gate-Emitter Voltage	C-E Short	±20V	V
I _C	DC Continuous Collector Current	T _C =100°C	50	A
I _{CM}	Pulse Collector Current	t _p =1ms, Note1	100	A
P _C	Maximum Power Dissipation	T _C =25°C, T _j =150°C(IGBT)	350	W
I _F	Diode forward Current	-	50	A
I _{FRM}	Repetitive peak forward Current	t _p =1ms, Note1	100	A
I ² t	I ² t-value	V _R =0V, t _p =10ms, T _j =25°C (Diode)	2000	A ² s
t _{sc}	Short Circuit Withstand Time	V _{GE} =15V, V _{CE} =600V, T _j =150°C	10	us
T _{jmax}	Max junction temperature	-	175	°C
T _{jop}	Operating junction temperature	-	-40 to 150	°C
T _{stg}	Storage temperature	-	-40 to 125	°C

Note1: Pulse width limited by maximum junction temperature

NTC characteristics

Symbol	Parameter	Condition	Value			Unit
			Min.	Typ.	Max.	
R ₂₅	Resistance	T _C =25°C	-	5	-	kΩ
ΔR/R	Deviation of R100	T _C =100°C, R ₁₀₀ =493Ω	-5	-	5	%
P ₂₅	Power dissipation	T _C =25°C	-	-	20	mW
B _{25/50}	B-value	R ₂ = R ₂₅ exp [B _{25/50} (1/T ₂ - 1/(298,15 K))]	-	3375	-	K
B _{25/80}	B-value	R ₂ = R ₂₅ exp [B _{25/80} (1/T ₂ - 1/(298,15 K))]	-	3411	-	K
B _{25/100}	B-value	R ₂ = R ₂₅ exp [B _{25/100} (1/T ₂ - 1/(298,15 K))]	-	3433	-	K

IGBT Electrical characteristics (T_j=25°C unless otherwise specified, chip)

Symbol	Item	Condition		Value			Unit	
				Min.	Typ.	Max		
V _{CE(sat)}	Collector-Emitter Saturation Voltage	I _C =50A V _{GE} =15V	T _j =25°C	-	1.5	-	V	
			T _j =125°C	-	1.7	-	V	
			T _j =150°C	-	1.8	-	V	
V _{GE(th)}	Gate-Emitter threshold Voltage	I _C =20mA, V _{CE} =V _{GE}		4.5	5.2	5.7	V	
Q _G	Gate charge	V _{GE} = -15V to +15V		-	490	-	nC	
R _{Gint}	Internal gate resistor	f=1M, V _{pp} =1V	T _j =25°C	-	2.3	-	Ω	
C _{ies}	Input Capacitance	V _{CE} =25V, V _{GE} =0V f=1MHz	T _j =25°C	-	5.2	-	nF	
C _{oes}	Output Capacitance			-	0.69	-	nF	
C _{res}	Reverse transfer Capacitance			-	0.45	-	nF	
I _{CES}	Collector- Emitter Cut off Current	V _{CE} =1200V, V _{GE} =0V		T _j =25°C	-	-	1	mA
I _{GES}	Gate-Emitter Leakage Current	V _{GE} =20V, V _{CE} =0V		T _j =25°C	-	-	200	nA
t _{d(on)}	Turn-on delay time	V _{CC} =600V I _C =50A V _{GE} =+15V/-8V R _{Gon} =R _{Goff} =15Ω Inductive load	T _j =25°C	-	90	-	ns	
			T _j =150°C	-	92	-		
t _r	Rise time		T _j =25°C	-	38	-	ns	
			T _j =150°C	-	38	-		
t _{d(off)}	Turn-off delay time		T _j =25°C	-	512	-	ns	
			T _j =150°C	-	590	-		
t _f	Fall time		T _j =25°C	-	182	-	ns	
			T _j =150°C	-	348	-		
E _{on}	Turn-on power dissipation		T _j =25°C	-	2.6	-	mJ	
			T _j =150°C	-	4.4	-		
E _{off}	Turn-off power dissipation		T _j =25°C	-	3.5	-	mJ	
			T _j =150°C	-	5.7	-		
R _{th(j-c)}	Thermal Resistance, Junction to Case (IGBT)		-	-	0.34	°C/W		
R _{th(c-s)}	Thermal Resistance, Case to sink (Conductive Grease applied)		-	0.05	-	°C/W		

Freewheeling Diode Electrical characteristics (T_j=25°C unless otherwise specified, chip)

Symbol	Item	Condition	Value			Unit	
			Min.	Typ.	Max		
V _F	Diode Forward Voltage	I _F = 50A, V _{GE} = 0V	T _j = 25°C	-	1.6	-	V
			T _j = 150°C	-	1.4	-	
t _{rr}	Diode Reverse Recovery Time	(Switch side) V _{CC} = 600V, I _C = 50A V _{GE} = +15V/-8V	T _j = 25°C	-	256	-	ns
			T _j = 150°C	-	438	-	
I _{RM}	Peak reverse recovery Current	R _{Gon} = R _{Goff} = 15Ω	T _j = 25°C	-	35	-	A
			T _j = 150°C	-	40	-	
Q _{rr}	Recovered charge	(FRD side) V _{rr} = 600V, I _F = 50A V _{GE} = +15V/-8V	T _j = 25°C	-	5.5	-	uC
			T _j = 150°C	-	13.0	-	
E _{rr}	Reverse recovered energy	Inductive load switching operation	T _j = 25°C	-	2.1	-	mJ
			T _j = 150°C	-	5.1	-	
R _{th(j-c)}	Thermal Resistance, Junction to Case (Diode)		-	-	0.54	°C/W	
R _{th(c-s)}	Thermal Resistance, Case to sink (Conductive Grease applied)		-	0.05	-	°C/W	

Test Conditions

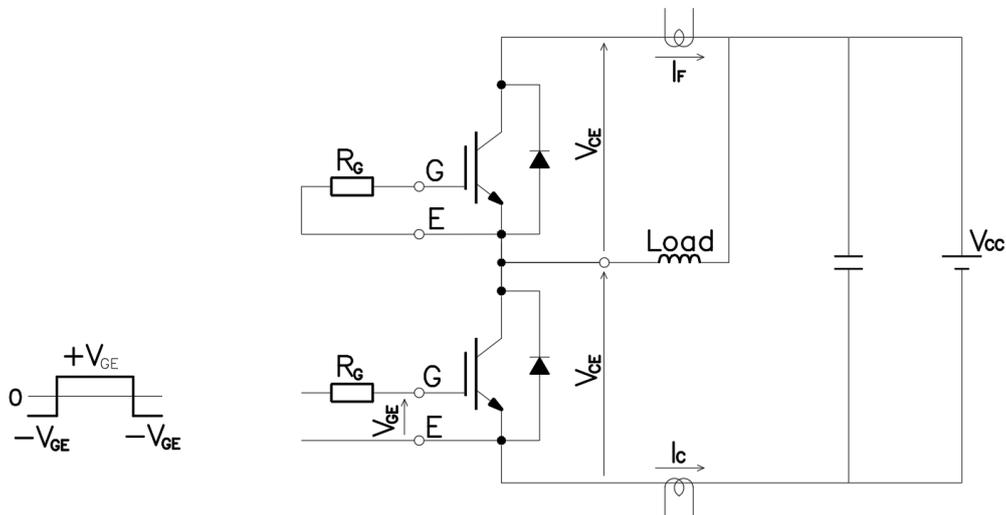

Figure 3. Switching time measure circuit

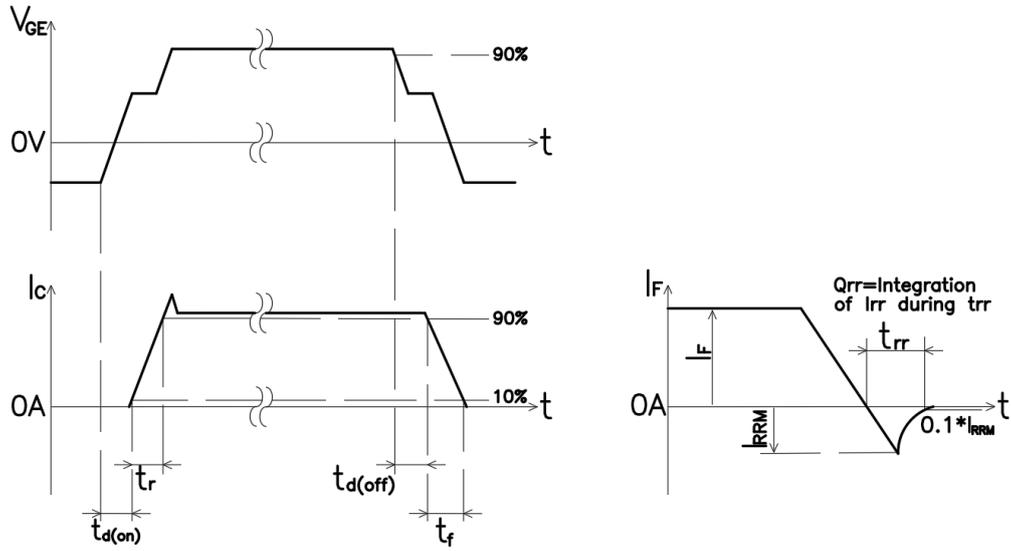
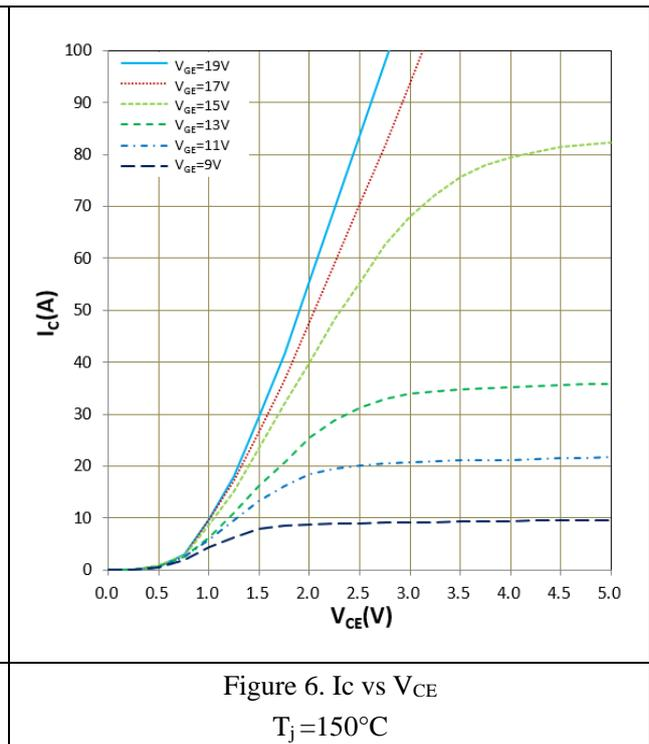
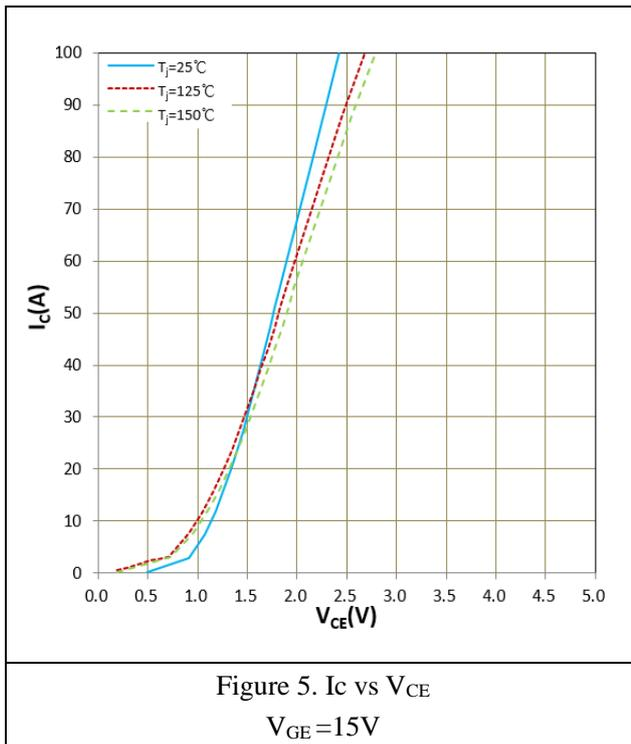

Figure 4. Switching time definition



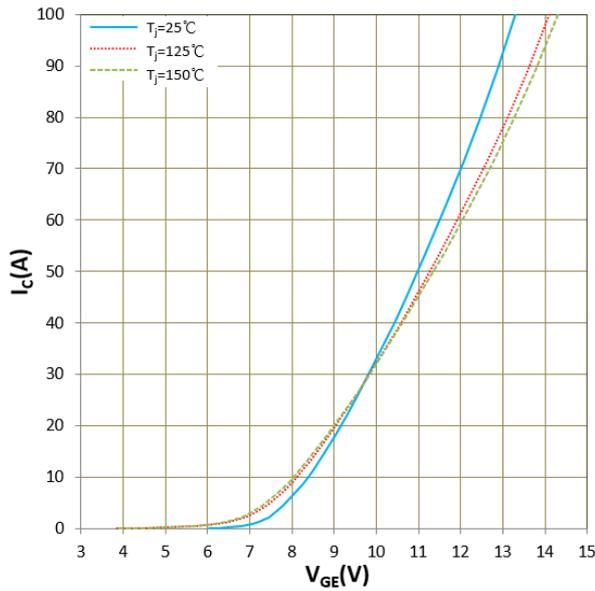

Figure 7. I_c vs V_{GE}
 $V_{CE} = 20V$

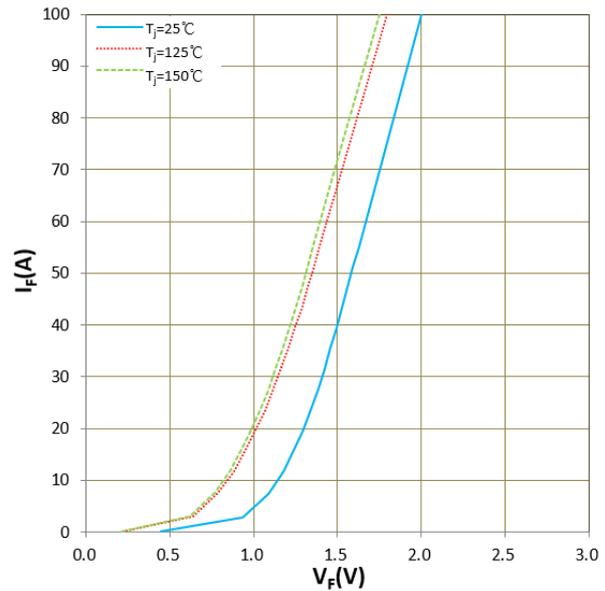

Figure 8. I_F vs V_F

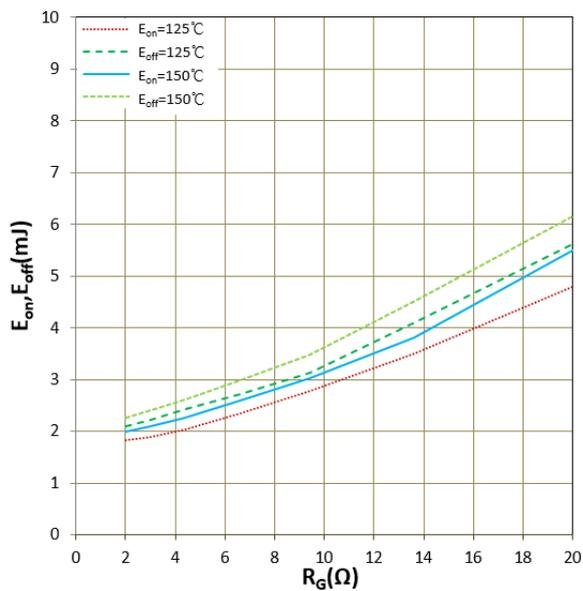

Figure 9. E_{on} , E_{off} vs R_G (Typ)
 $V_{CC} = 600V$, $V_{GE} = +15V/-8V$, $I_c = 50A$
Inductive Load

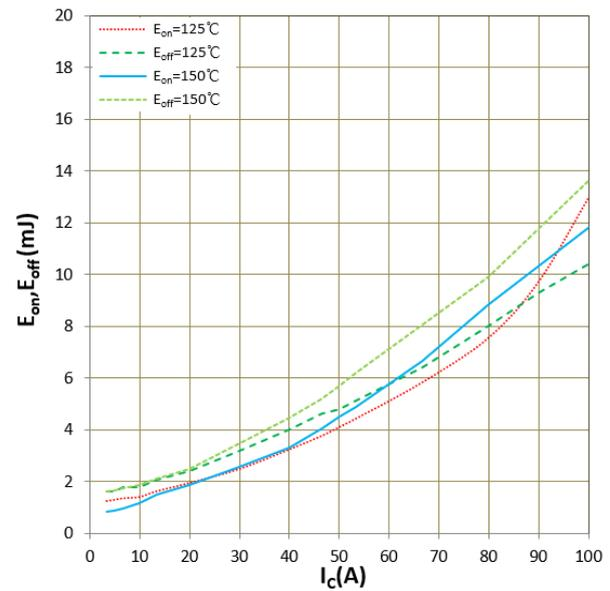

Figure 10 E_{on} , E_{off} vs I_c (Typ)
 $V_{CC} = 600V$, $V_{GE} = +15V/-8V$, $R_{Gon} = R_{Goff} = 15\Omega$
Inductive Load

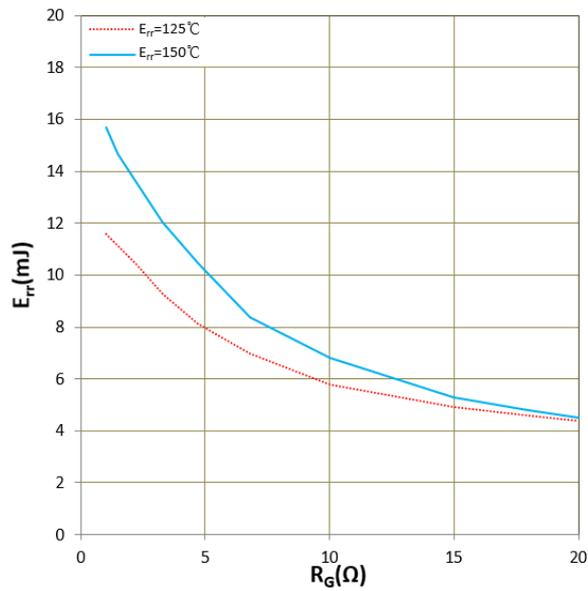

Figure 11. Err vs R_G(Typ)
 $V_{CC}=600V, V_{GE}=+15V/-8V, I_F=50A$
 Inductive Load

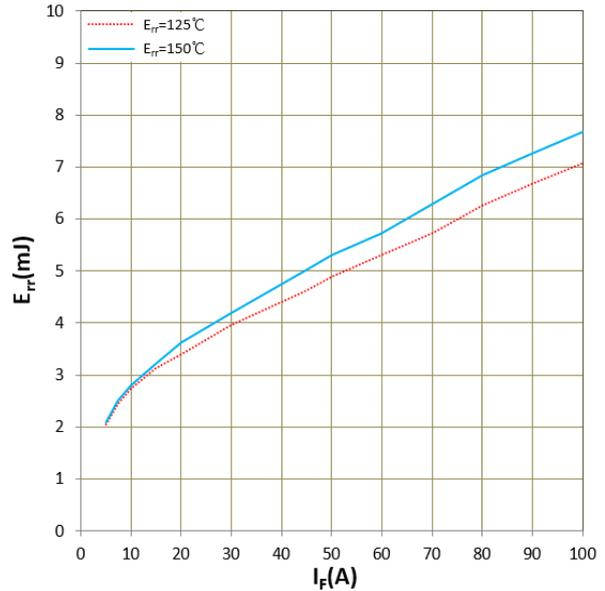

Figure 12. E_{rr} vs I_F(Typ)
 $V_{CC}=600V, V_{GE}=+15V/-8V, R_{Gon} = R_{Goff} = 15\Omega$
 Inductive Load

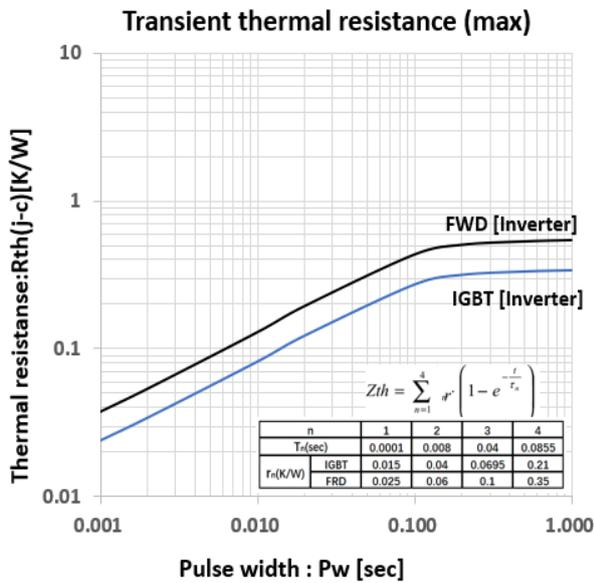

Figure 13. Transient thermal resistance

IMPORTANT NOTICE:

This product data sheet describes the characteristics of this product for which a warranty is granted. Any such warranty is granted exclusively under the terms and conditions of the supply agreement. There will be no guarantee or of any kind for the product and its characteristics.

The data contained in this document is exclusively intended for technically trained staff. You and your technical departments will have to evaluate the product's suitability for the intended application and the completeness of the product data concerning such application.

Due to technical requirements, our product may contain dangerous substances. For information on the types in question, please contact the sales staff responsible for you.

Changes to this product data sheet are reserved.

Please contact the sales staff (Sales@leapers-power.com) for further information on the product, technology, delivery terms, conditions and prices.