

Description

The DFS300HF14I3Q1 is a Half Bridge SiC MOSFET Power Module. It integrates high performance SiC MOSFET chips designed for the applications such as Motor drives and Renewable energy.



Features

- Blocking voltage 1400V
- $R_{DS(on)} = 6.6m\Omega @ T_j = 25^\circ C, V_{GS} = 20V$
- Low thermal resistance with Si₃N₄ AMB
- 175°C maximum junction temperature
- Low Inductive Design
- Thermistor inside
- Low Switching Losses

Applications

- xEV Applications
- Motor Drives
- Vehicle Fast Chargers
- Renewable energy

Circuit diagram

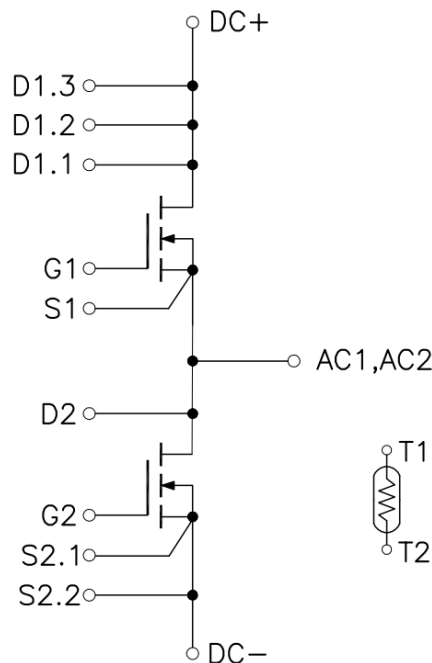

Figure 1. Out drawing & circuit diagram for DFS300HF14I3Q1

Note: Please use **S2.1** for the low side drive signal and do not connect it to **S2.2** which is power terminal

Pin Configuration and Marking Information

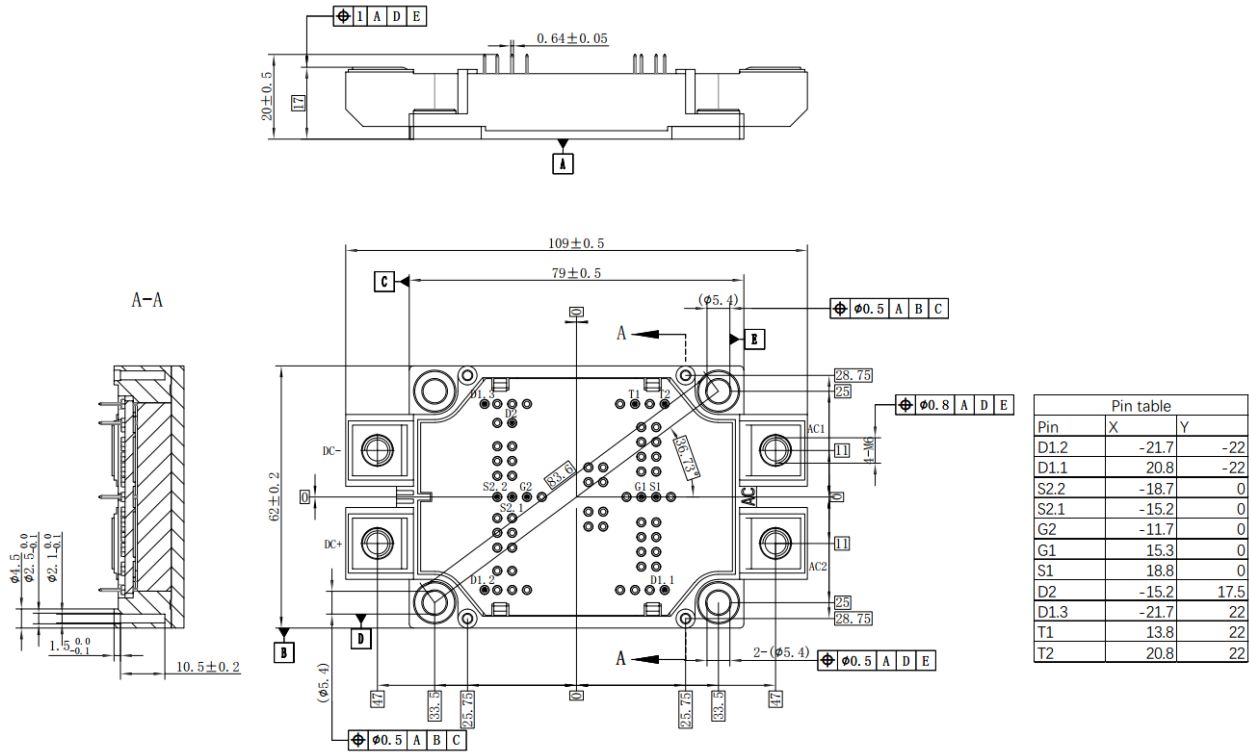

Figure 2. Pin configuration

Module

Parameter	Conditions	Value	Unit
Isolation Voltage	RMS, f =50Hz, t =1min	4.0	kV
Material of module baseplate	-	Cu	-
Creepage distance	terminal to heatsink terminal to terminal	14.5 13	mm
Clearance	terminal to heatsink terminal to terminal	12.5 10	mm
CTI	-	>400	-
Module lead resistance, terminals–chip	T _c =25°C	0.3	mΩ
Mounting torque for module mounting	M5, M6	3 to 6	Nm
Weight	-	250	g

Maximum Ratings (T_j = 25°C unless otherwise specified)

Symbol	Parameter	Conditions	Ratings	Unit
V _{DSS}	Drain-Source Voltage	G-S Short	1400	V
V _{DS nom}	Continuous Operating DC Voltage	Not include surge voltage	1100	V
V _{GSS}	Gate-Source Voltage	D-S Short, AC frequency ≥ 1Hz, Note1	-10 to 25	V
I _{DS}	DC Continuous Drain Current	T _C = 80°C, V _{GS} = 20V	300	A
I _{DS}	DC Continuous Drain Current	T _C = 120°C, V _{GS} = 20V	220	A
I _{SD}	Source (Body diode) Current	T _C = 80°C, with ON signal	300	A
I _{SD}	Source (Body diode) Current	T _C = 120°C, with ON signal	220	A
I _{DSM}	Pulse Forward Current	T _C = 25°C, Pulse width = 1ms, V _{GS} = 20V, Note2	600	A
P _{tot}	Total Power Dissipation	T _C = 25°C	1800	W
T _{jmax}	Max Junction Temperature	-	175	°C
T _{stg}	Storage Temperature	-	-40 to 125	°C

Note1: Recommended Operating Value, +20V/-5V, +18V/-5V, +15V/-4V

Note2: Pulse width limited by maximum junction temperature

NTC characteristics

Symbol	Parameter	Condition	Value			Unit
			Min.	Typ.	Max.	
R ₂₅	Resistance	T _C = 25°C	-	5	-	kΩ
ΔR/R	Deviation of R100	T _C = 100°C, R ₁₀₀ = 493Ω	-5	-	5	%
P ₂₅	Power dissipation	T _C = 25°C	-	-	20	mW
B _{25/50}	B-value	R ₂ = R ₂₅ exp [B _{25/50} (1/T ₂ - 1/(298,15 K))]	-	3375	-	K
B _{25/80}	B-value	R ₂ = R ₂₅ exp [B _{25/80} (1/T ₂ - 1/(298,15 K))]	-	3411	-	K
B _{25/100}	B-value	R ₂ = R ₂₅ exp [B _{25/100} (1/T ₂ - 1/(298,15 K))]	-	3433	-	K

MOSFET Electrical characteristics (T_j=25°C unless otherwise specified, chip)

Symbol	Item	Condition	Value			Unit	
			Min.	Typ.	Max		
V _{(BR)DSS}	Drain-Source Breakdown Voltage	V _{GS} =0V, I _D =3mA	1400	-	-	V	
I _{DSS}	Zero gate voltage drain Current	V _{DS} =1400V, V _{GS} =0V	-	3	-	μA	
V _{GS(th)}	Gate-source threshold Voltage	I _D =60mA	1.8	2.5	4.0	V	
		V _{DS} =V _{GS}					
I _{GSS}	Gate-Source Leakage Current	T _j =25°C	-	100	600	nA	
		T _j =175°C					
R _{DS(on)} (Chip)	Static drain-source On-state resistance	I _D =300A V _{GS} =20V	T _j =25°C	-	6.6	-	mΩ
			T _j =175°C	-	12.4	-	mΩ
		I _D =300A V _{GS} =18V	T _j =25°C	-	7.1	-	mΩ
			T _j =175°C	-	12.9	-	mΩ
V _{DS(on)} (Chip)	Static drain-source On-state Voltage	I _D =300A V _{GS} =20V	T _j =25°C	-	2.0	-	V
			T _j =175°C	-	3.7	-	V
		I _D =300A V _{GS} =18V	T _j =25°C	-	2.1	-	V
			T _j =175°C	-	3.9	-	V
C _{iss}	Input Capacitance	V _D =1000V, V _{GS} =0V f =200kHz, V _{AC} =25mV	-	18.9	-	nF	
C _{oss}	Output Capacitance		-	1.08	-	nF	
C _{rss}	Reverse transfer Capacitance		-	0.11	-	nF	
Q _G	Total gate charge	V _{DD} =800V, I _D =150A, V _{GS} =+20/-5V	-	650	-	nC	
R _{Gint}	Internal Gate Resistance	T _j =25°C	-	1.3	-	Ω	
t _{d(on)}	Turn-on delay time	V _{DD} =600V I _D =300A V _{GS} =+18/-5V R _{G(on)} =3.3Ω R _{G(off)} =3.3Ω Inductive load switching operation	T _j =25°C	-	45	-	ns
			T _j =150°C	-	41	-	
t _r	Rise time		T _j =25°C	-	36	-	ns
			T _j =150°C	-	32	-	
t _{d(off)}	Turn-off delay time		T _j =25°C	-	35	-	ns
			T _j =150°C	-	44	-	
t _f	Fall time		T _j =25°C	-	17	-	ns
			T _j =150°C	-	20	-	
E _{on}	Turn-on power dissipation		T _j =25°C	-	7.5	-	mJ
			T _j =150°C	-	10.4	-	
E _{off}	Turn-off power dissipation	T _j =25°C	-	1.8	-	mJ	
		T _j =150°C	-	3.0	-		
R _{th(j-c)}	FET Thermal Resistance	Junction to Case	-	0.08	-	K/W	
R _{th(c-f)}	Contact thermal Resistance	With thermal conductive grease, Note3	-	0.015	-	K/W	

Note3: Assumes Thermal Conductivity of grease is 0.9W/m · K and thickness is 50um.

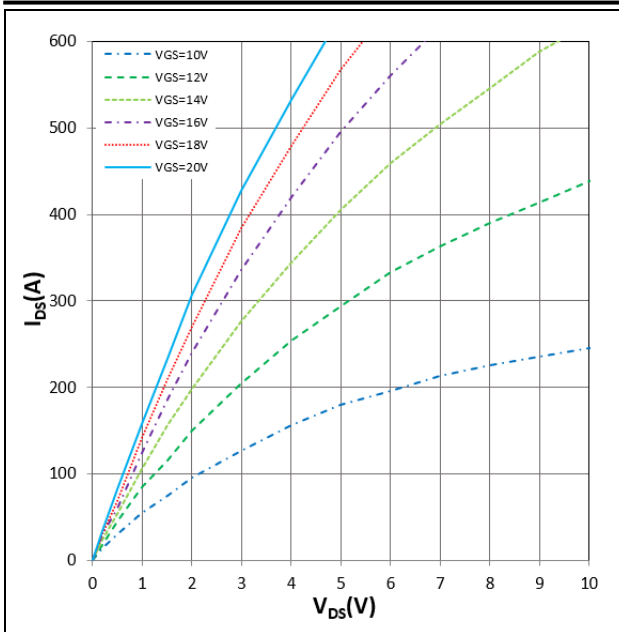

Figure 5. I_{DS} vs V_{DS}
 $T_j = 25^\circ\text{C}$, V_{GS} parameter

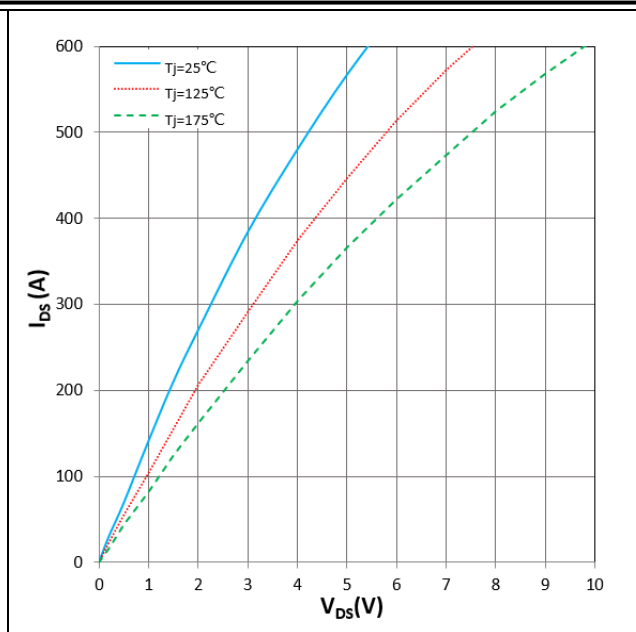

Figure 6. I_{DS} vs V_{DS}
 $V_{GS} = 18\text{V}$, T_j parameter

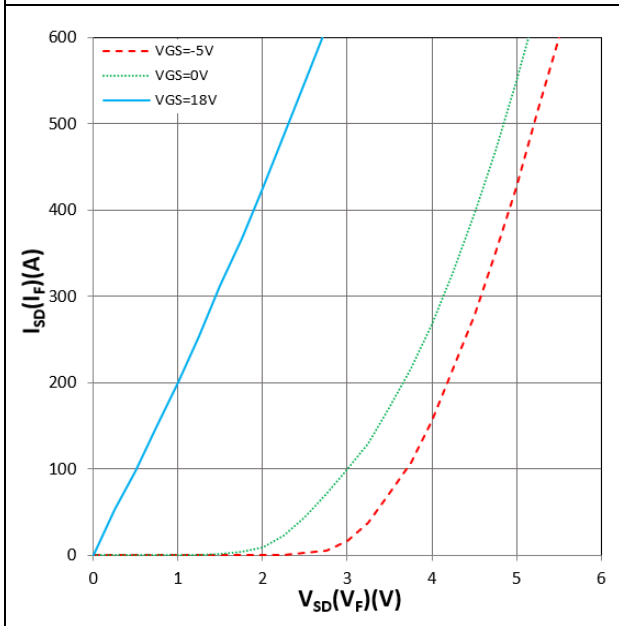

Figure 7. $I_{SD}(I_F)$ vs $V_{SD}(V_F)$
 $T_j = 25^\circ\text{C}$, V_{GS} parameter

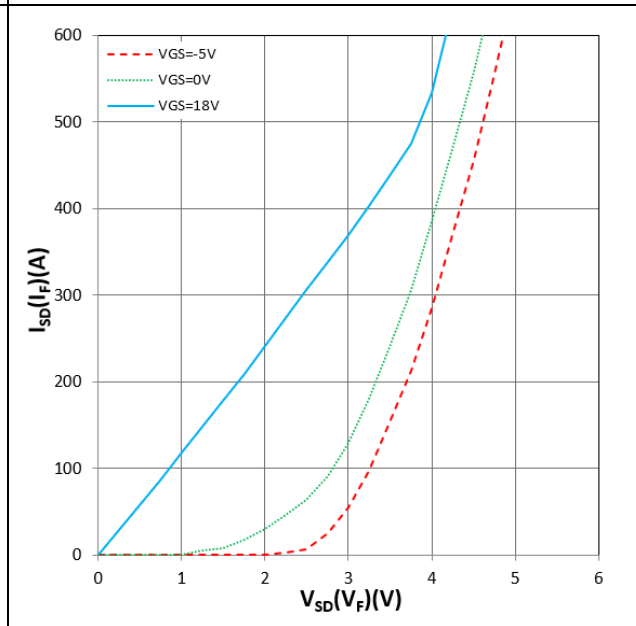

Figure 8. $I_{SD}(I_F)$ vs $V_{SD}(V_F)$
 $T_j = 175^\circ\text{C}$, V_{GS} parameter

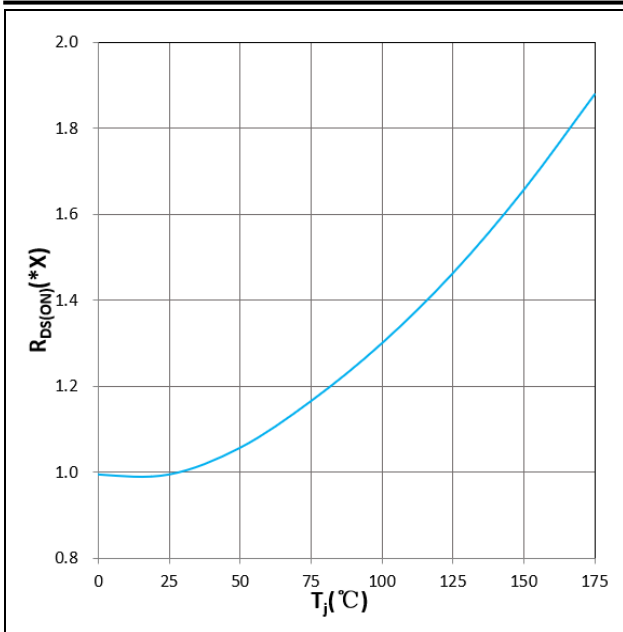

Figure 9. $R_{DS(ON)}$ vs T_j
 $V_{GS}=+20V, I_D=300A, 1.0X=6.6m\Omega$

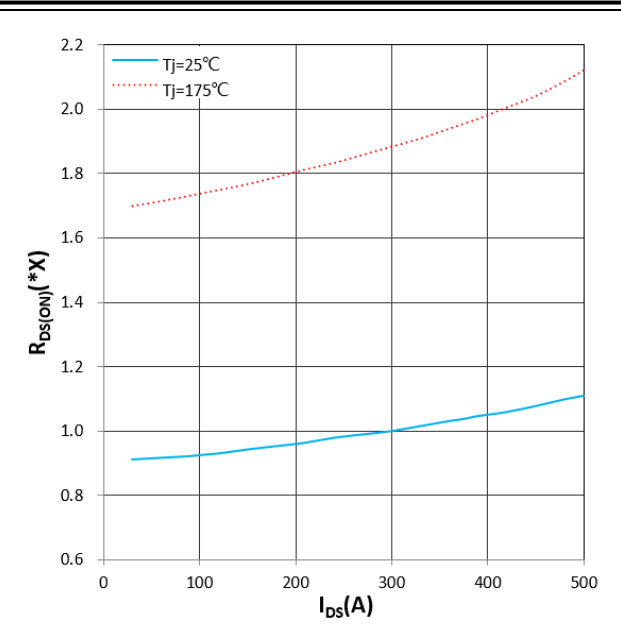

Figure 10. $R_{DS(ON)}$ vs I_{DS}
 $T_j=25^\circ C/175^\circ C, V_{GS}=+20V, 1.0X=6.6m\Omega$

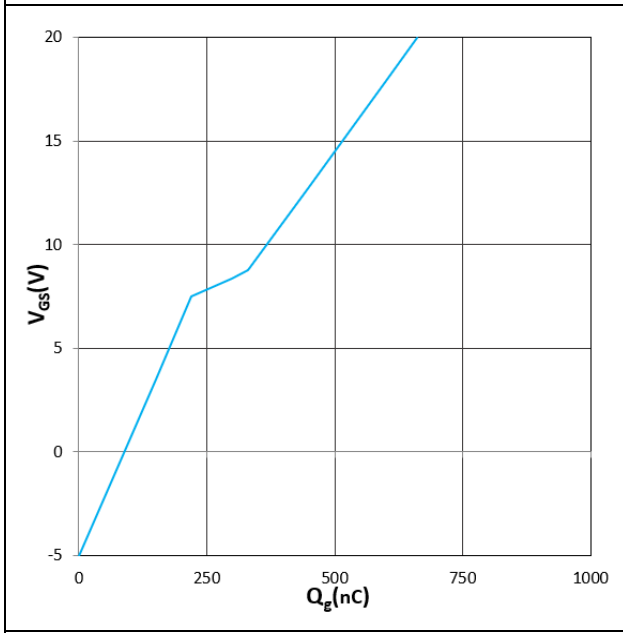

Figure 11. V_{GS} vs Q_g
 $T_j=25^\circ C, V_{DS}=800V, I_D=150A$

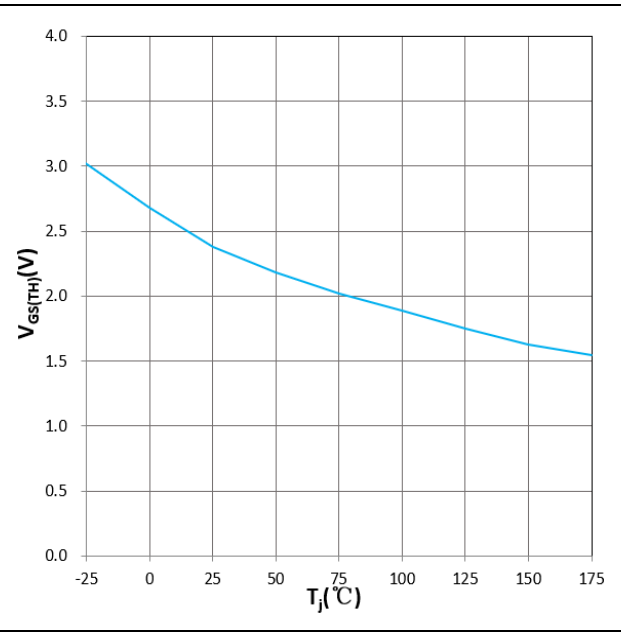

Figure 12. $V_{GS(TH)}$ vs T_j
 $V_{GS}=V_{DS}, I_D=60mA$

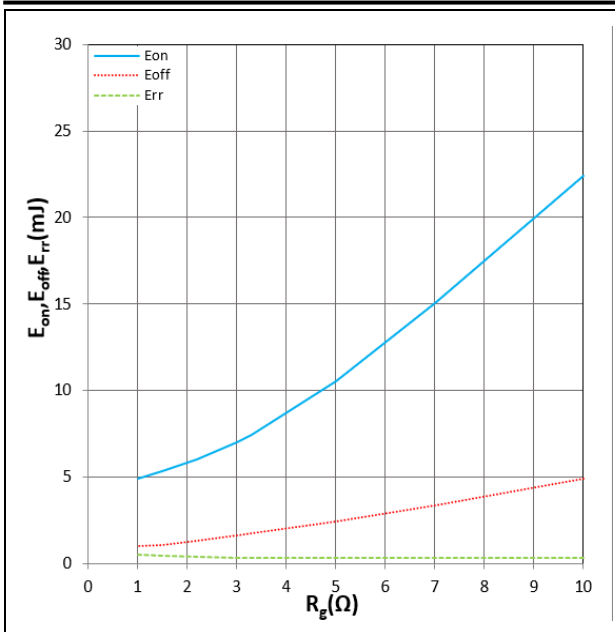

Figure 13. E_{on} , E_{off} , E_{rr} vs R_g
 $T_j=25^\circ\text{C}$, $V_{DD}=600\text{V}$, $V_{GS}=+18\text{V}/-5\text{V}$, $I_D=300\text{A}$
 Inductive Load

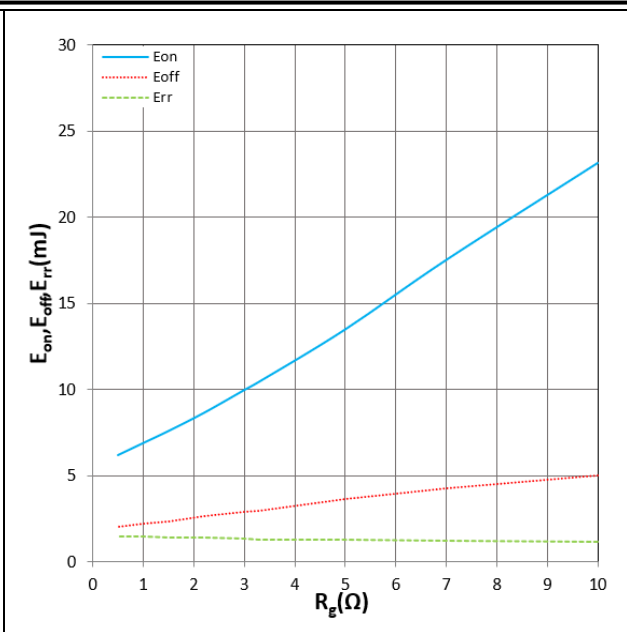

Figure 14. E_{on} , E_{off} , E_{rr} vs R_g
 $T_j=150^\circ\text{C}$, $V_{DD}=600\text{V}$, $V_{GS}=+18\text{V}/-5\text{V}$, $I_D=300\text{A}$
 Inductive Load

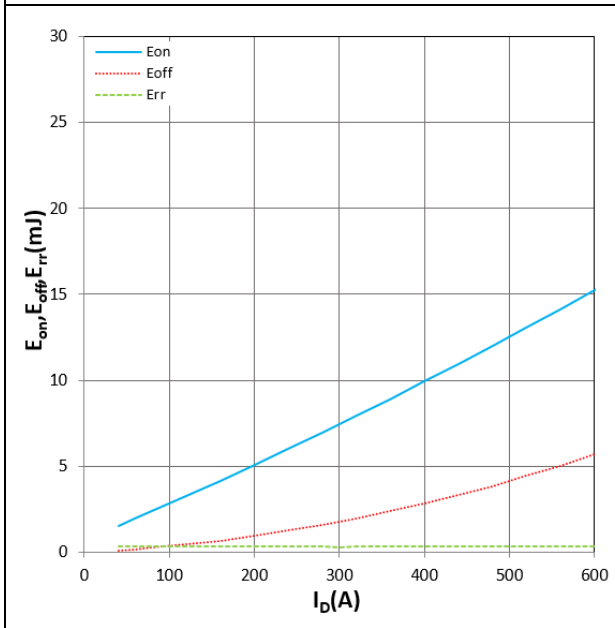

Figure 15. E_{on} , E_{off} , E_{rr} vs I_D
 $T_j=25^\circ\text{C}$, $V_{DD}=600\text{V}$, $V_{GS}=+18\text{V}/-5\text{V}$, $R_g=3.3\Omega$
 Inductive Load

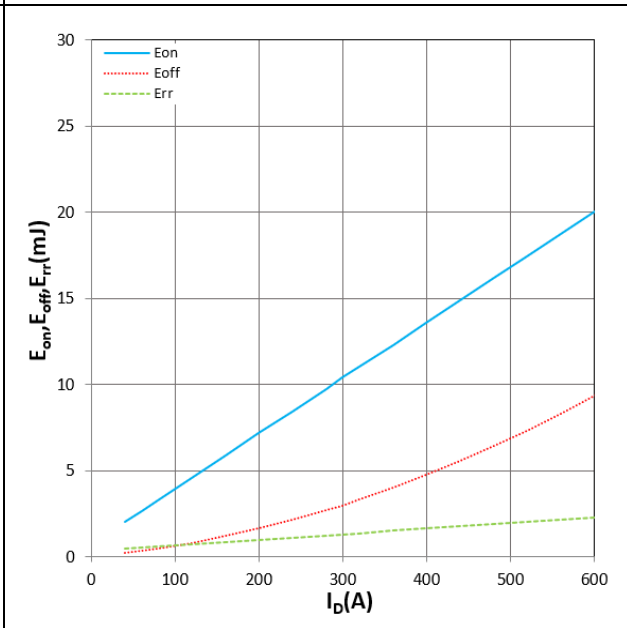

Figure 16. E_{on} , E_{off} , E_{rr} vs I_D
 $T_j=150^\circ\text{C}$, $V_{DD}=600\text{V}$, $V_{GS}=+18\text{V}/-5\text{V}$, $R_g=3.3\Omega$
 Inductive Load

IMPORTANT NOTICE:

This product data sheet describes the characteristics of this product for which a warranty is granted. Any such warranty is granted exclusively under the terms and conditions of the supply agreement. There will be no guarantee or of any kind for the product and its characteristics.

The data contained in this document is exclusively intended for technically trained staff. You and your technical departments will have to evaluate the product's suitability for the intended application and the completeness of the product data concerning such application.

Due to technical requirements, our product may contain dangerous substances. For information on the types in question, please contact the sales staff responsible for you.

Changes to this product data sheet are reserved.

Please contact the sales staff (Sales@leapers-power.com) for further information on the product, technology, delivery terms, conditions and prices.